

Traditional 60 classic

As of: April 08, 2026

Description	Model	Carton Quantity
TUK252-24X2B	T252	100 pc per carton

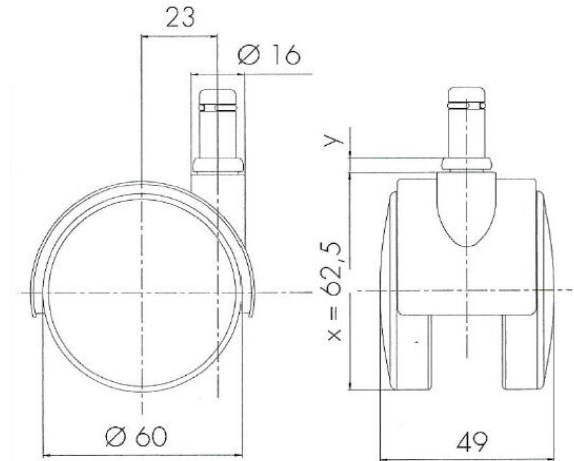

## Technical Details

Product Type	Furniture or Chair Caster
Wheel diameter	60mm   2 ½"
Load capacity	58kg   127 lbs.
Overall height with fixing	65.2mm
<b>Wheel:</b>	
Wheel type	softwheel
Wheel core / tread color	Black / Black
<b>Housing:</b>	
Housing form	hooded
Neck diameter	16mm
Housing material	High quality nylon
Housing color	Black
Mobility concept	Freewheel
Fixing	11x22mm Push-fit stem
Description	TUK252-24X2B

## Fixings

Compatible with the following available fixings:

### Push fit stems:

- 10x20mm with 10.3mm circlip
- 10x22mm with 10.5mm circlip
- 11x19.5mm with 11.8mm circlip
- 11x22mm with 11.4mm circlip
- 11x22mm with 11.6mm circlip
- 11x22mm with 11.8mm circlip
- 11x22mm with 11.8 banded K290 4A
- 11x26mm

### Threaded stems:

- 3/8-16x1"
- 3/8x1"

### Square plates:

- 38x38mm
- 55x55mm
- 60x60mm