

## Traditional 100 Single Wheel

As of: July 07, 2026

Description	Model	Carton Quantity
SWF100-2XM10X25	SW100	100 pc per carton

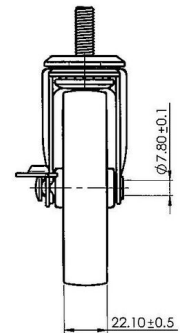
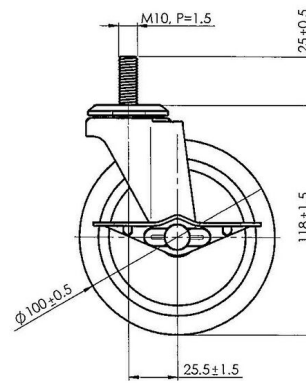

### Technical Details

Product Type	Furniture caster
Wheel diameter	100mm   4"
Load capacity	45kg   99 lbs.
Overall height with fixing	119mm
<b>Wheel:</b>	
Wheel type	hardwheel
Wheel color	Black
<b>Housing:</b>	
Housing form	unhooded
Housing material	Galvanized steel
Housing color	Chrome
Mobility concept	Freewheel, Chrome
Fixing	M10X25mm Threaded stem
Description	SWF100-2XM10X25

## Fixings

Compatible with the following available fixings:

### Push fit stems:

- 10x20mm with 10.3mm circlip
- 10x22mm with 10.5mm circlip
- 11x19.5mm with 11.8mm circlip
- 11x22mm with 11.4mm circlip
- 11x22mm with 11.6mm circlip
- 11x22mm with 11.8mm circlip
- 11x22mm with 11.8 banded K290 4A
- 11x26mm

### Threaded stems:

- 3/8-16x1"
- 3/8x1"

### Square plates:

- 38x38mm
- 55x55mm
- 60x60mm